

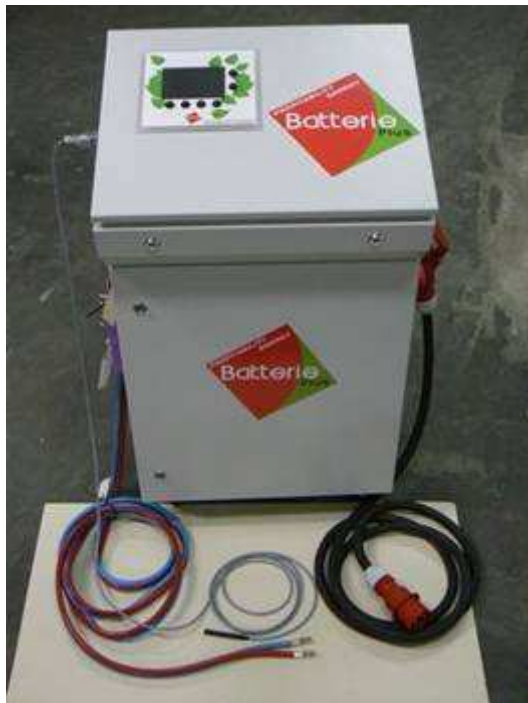

Lead acid / gel Battery Regeneration

SERVICE MANUAL

Equipment: BRT 20-3





CONTENT

<u>I. FOREWORD</u>	3
<u>II. SAFETY REQUIREMENTS</u>	6
2.1 REMOVING THE BRT FROM THE CRATE	6
2.2 EQUIPMENT INSTALLATION AND ENVIRONMENT	7
2.3 CAUTION	7
2.4 CONNECTING THE EQUIPMENT	8
2.5 CHOSE YOUR LANGUAGE AND SELECT THE ALTERNATE CURRENT FREQUENCY	9
2.6 AIRVENT IN THE WORKSHOP.....	10
2.7 REQUIRED EQUIPMENT	10
2.7.1 REGENERATION EQUIPMENT	11
2.7.2 STAFF SAFETY EQUIPMENT.....	11
<u>III. REGENERATION PROCESS</u>	12
3.1 GETTING READY AND START UP	12
3.1.1 BATTERY PREPARATION.....	12
3.1.2 CONTROL AND BATTERY CELLS MEASUREMENT.....	13
a) Cell voltage	13
b) Cells acid density	14
3.1.3 ELECTROLYTE LEVEL CONTROL	14
3.1.4 BATTERY(IES) CONNECTION TO THE BRT	15
3.1.5 TEMPERATURE GAUGE CONNECTION AND POSITIONNING.....	16
3.1.6 PLUG TO THE MAIN POWER SUPPLY	17
3.2 STARTING UP THE REGENERATION PROCESS.....	17
a) Charge by pulse	23
b) Constant charge	24
3.2.2 AUTOMATIC PROGRAM FOR TRACTION BATTERIES.....	26
3.2.3 START MODE DEDICATED TO 12 V STARTING BATTERIES	28
3.2.4 STATIONARY BATTERIES.....	33
3.2.5 MODIFYING OR SETTING UP A NEW PROGRAM.....	36
3.2.6 NORMAL CHARGE	37
3.3 CONTROL AND REGENERATION ACKNOWLEDGMENT	38
3.3.1 HIGH TEMPERATURE	38
3.3.2 « HIGH VOLTAGE»	39
3.3.3 END OF REGENERATION LOOPS.....	40
3.3.4 CONTROL ON THE DISCHARGER ANALYZER FOR ACKNOWLEDGMENT	40
3.3.5 REGENERATION CONTROL ON ELECTROLYTE AND VOLTAGE.....	41
3.3.6 DISCONNECTING THE BATTERY	42



4	TECHNICAL APPENDICES.....	44
4.1	EQUIPMENT SCHEME DESCRIPTION	44
4.2	INSTALLATION	44
4.3	MAINTENANCE AND EQUIPMENT CHECK LIST	45
4.4	CHECKING THE TEMPERATURE GAUGE CONNECTION	46
4.5	BREAKDOWN ANALYSIS.....	47
4.5.1	ELECTRIC INTERRUPTION	47
4.5.2	REGENERATOR GETS OVERHEATED	47
4.5.3	TEMPERATURE GAUGE	47
4.5.4	OUTPUT DISPLAYS 100 %	48
4.5.5	REGENERAION DOESN'T START	48
4.5.6	NO ELECTRIC FLOW ON SCREEN	48
4.5.7	WORKSHEET "REGENERATION TEST"	48



I. Foreword

This comprehensive operator's manual is dedicated to the users of lead acid / gel battery regenerator: BRT 20

It shall be used as the operation as well as a reference manual.

It is based on the manufacturer's technical documents issued by him and he shall be the only liable person regarding its contents.

It describes all the functions of the equipment and explains how the operator shall proceed at each stage of the regeneration process in order to preserve the user's safety as well as the normal use of the equipment.

Caution: one shall read carefully this manual before starting up the equipment. Specific attention shall be drawn on the safety requirements during the regeneration process as well as for the batteries manipulation.

This product has been manufactured in accordance with high quality norms and comply with the CE European standards. BRT 20 regenerator is based on a high tech process allowing the recovery of the original traction lead acid battery capacities after enduring an electrochemical treatment. As a result, battery will get an extended life span, a greater efficiency and de facto their operating cost will drop. The process mainly applies to traction lead acid or gel batteries, which are usually used in the electric forklifts, electric elevators, cleaning machines, golf cart type vehicles and other electric tractor and equipment. Process concerns Stationary and starting lead batteries as well.

This equipment is not suitable for other type of batteries, namely the ones using other material than lead.

As everyone knows, battery capacity is decreasing yearly, and after a few years it almost remains only 25% of the original characteristics.

During normal discharge of the battery, one can observe that oxides, lead sulphate crystals and water emerge. Usually those components are recovering their original stage (i.e. lead and sulphuric acid) once the battery is charged again. From the very first battery charge, lead sulphate crystal are emerging slowly and growing constantly. Those crystals are the main cause of the battery failure. All active agents within the battery are then solid and the electrochemical reaction can not work properly, thus reducing the electricity generation.

During charging process, a battery on which oxide and lead sulphate appear on the electrodes, may get overheated. Electrodes may then weaken and some micro parts of those may drop on the bottom of the battery rack.

The BRT process is removing lead sulphate crystals on the electrodes. During regeneration process, lead parts return on the electrode dedicated surface. Electrodes get then covered with micro lead balls enlarging the electrode surface and then easing the charge.

Not only extending the battery life span, the regeneration process has also a positive impact on the battery lift carrier with direct impact on its productivity.



BATTERY DISCHARGE

During normal discharge process, electrodes generate on both side lead sulphating process.
 (White liquid).

Along cycles, this liquid will slowly turn to a solid crystal form.
 This emerging crystal will spread over the cycles and generate a capacity decrease of the battery.

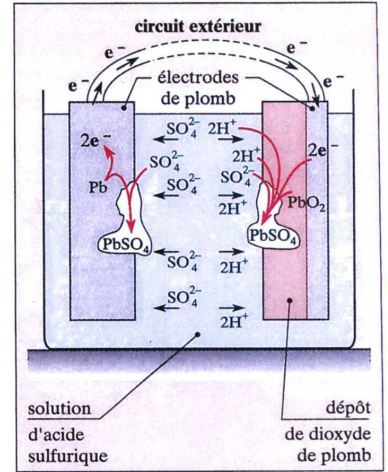

9. Circulation des porteurs de charge (→) et réactions électrochimiques (→) lors du fonctionnement d'un accumulateur au plomb.

CHARGING BATTERIES

When charging, the lead sulphation (white liquid) will split and reload electrodes and electrolyte.

Once the lead sulphate is solid, the classic chargers can not reload electrodes and electrolyte.
 Activ agents turn to crystal and will be off the normal path, weakening the battery capacity.

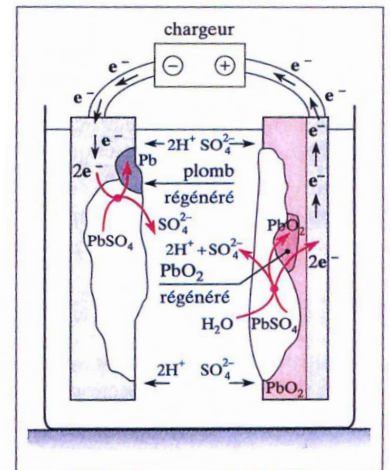

12. Circulation des porteurs de charge (→) et réactions électrochimiques (→) lors de la recharge d'un accumulateur au plomb.



Regeneration process removes the lead crystal sulphate for a total battery capacity recovery.

Regeneration can be conducted on a curative way (every 4/5 years) or on a preventive way (once a year).

Prevention allows to keep the total battery capacity during the full life of the forklift, preventing some electric failure to occur due to crystals growth and plaque distorsion.

Preventive regeneration process is conducted over short cycles (24h) whereas curative regeneration may take up to 96 hours.

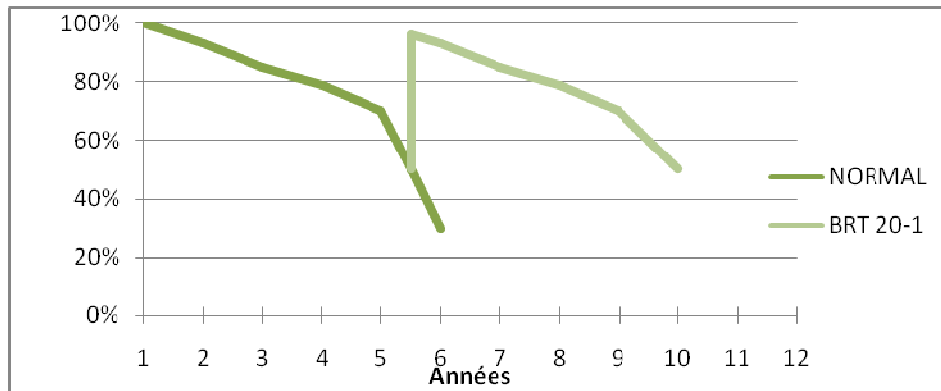

Curative regeneration on traction batteries

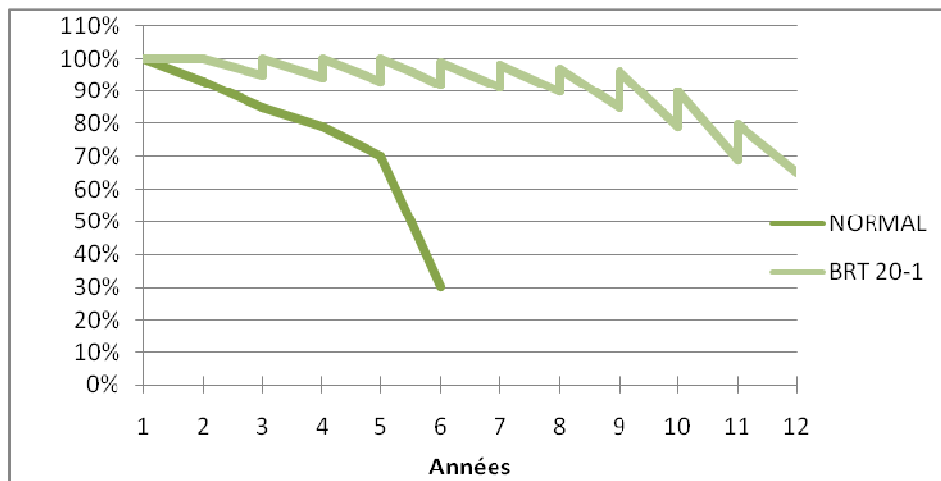

Preventive regeneration (once a year)



II. Safety requirements

2.1 Removing the BRT from the crate

The BRT is delivered strapped and wedged on a EUROPE type pallet with side extension.

	<p>Remove the top, then the side extensions and the bottom chock between the wheels. Cut the straps.</p>		<p>Remove the side chock.</p>
	<p>Push the BRT on the pallet edge</p>		<p>CAUTION : Leave the BRT rear frame on the pallet as shown ! Take the top of the crate and slide it under the wheels.*</p>
	<p>Slip a thin strap under the BRT</p>		<p>Move it till the second rim as shown !</p>
	<p>With two operators lift up the top of the BRT with the strap and let it stand on the edge of the pallet.</p>		<p>Once lift up the BRT makes automatically a soft landing on its wheels.</p>

***Upon height of the pallet it may be required to use the top of the crate or any other support to ease the contact of the wheels when lifting up the machine**



2.2 Equipment installation and environment

The regenerator shall be used indoor in a dry and clean place. If used outdoor, the BRT should be covered and in a dry place. No liquid shall stand close to the regenerator and the batteries. After refilling a battery with distilled water, make sure no water spilled on the floor, if so, remove it.

The regenerator shall be placed in a air vent room in accordance with the EN NFC15-100 Norma and any other local rules regarding safety.

Regenerator shall be placed on a flat floor. Keep all electricity input and battery connectors accessible. Main switch has to be accessible in case of quick disconnection requirement.

Battery shall be placed as far as cables allow from regenerator.
Contact between battery acid and the regenerator has to be strictly avoided.

2.3 Caution

No operation shall be started on the equipment without understanding how to handle it.

For individual and equipment safety concern, the following instructions shall be in force:

It is mandatory that the operator's manual shall be read entirely and fully understood before using the equipment.



Note : The equipment is under high voltage (380V). Contact with those components may be lethal.



Maintenance and repair procedure, which are not described herein, shall only be performed by the manufacturers' qualified staff.

Light maintenance described hereafter can be performed by a qualified electrician.

The operator shall only perform tasks as described in this manual.

Do not perform operations for which you haven't received the required training.

Do not use the regenerator if repairs are required on it.

Regenerator shall only be used for lead acid / gel batteries regeneration.

When performing maintenance, spare parts shall be ordered upon manufacturers specifications.

The equipment can not bear any retrofit or modification.



2.4 Connecting the equipment

For the set up please refer to chapter 4-2.



The regenerator shall only be connected to an approved dedicated plug in accordance with required voltage with appropriate phases.

Equipment requirements :

- 380/ 400 V Three phases+ Ground
- Differential electrical device 300mA or 500mA
- 40 to 50 A disruptor (D curve)

This machine is equipped with a CEM filter requiring earth connection of 5 mA. It is not required to connect this machine on a disruptor equipped with 300 mA differential (fire protection) or 500mA (machine protection on a dedicated connection).

A 30mA disruptor complying with the human body protection in the working place is sufficient.

Draw specific attention to the phase ranking.

If phases are inverted, the BRT will show malfunctioning such as:

- Global electric disruption
- Disruption after the first pulse (1 / 2 minutes after starting up)
- Pulse with very high amp volatility
- Big or discontinued noise during pulse;
- Output indicator: 100%

If the above occurs, phases shall be set in order. Report to chapter 4-2 hereafter.



**Do not connect a dry battery.
Any metallic item is banned within the battery environment.**

Cables to the main PSU should be checked and secured with no default. If not, this could be life threatening as high voltage is provided. If any doubt on cable integrity replace those by new ones.

Before connecting units to the BRT, make sure the regenerator is not plugged in. Screen display should show no indication.

Following sub units shall be connected as follows:

- Connect the battery first
- Then the temperature gauge shall be connected.
- At last the cable is connected to the main PSU.

Do not start up the BRT if the red and blue cables are not connected to the battery.

Do not connect battery cables to the regenerator unless they are already connected to the battery.



Air vents on the side of the BRT shall never be covered !

Unplug the battery cables from the regenerator’s side first before switching to another device or disconnecting the cables from the battery.

To disconnect the batteries, remove the connecting plug on the regenerator.

2.5 Chose your language and select the alternate current frequency

Once connected wait a few seconds before the main screen appears.



In the parameters menu you have access to :

- Total running time of the BRT
- Change the language of the menu
- Set the alternating current (50/60 Hz)
- Update the software with via USB port

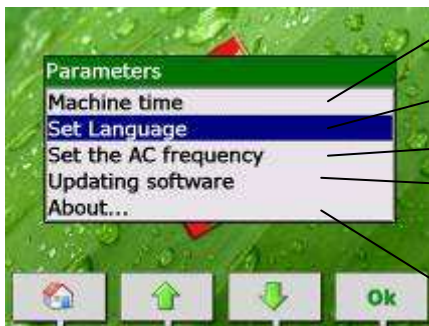

Serial number of the processor appears in the "about" window



2.6 Airvent in the workshop



**Smoking is prohibited
Sparks are banned (welding, grinding, etc.)**



During regeneration and normal charging, oxy hydrogen gas is generated ! However during the BRT process the explosive gas formation is reduced as constant current applies only during 5% of the total cycle. Anyhow flame and spark should be avoided.

Air vent or air cooling is required according to the Norma in force.

2.7 Required equipment

Caution:

- 1- Beware; it is dangerous to work close to lead acid batteries. When in tension, some explosive gases are produced by the battery. Reading the service manual and referring to it all the time is then mandatory.
- 2- To reduce explosive risks, one must refer to the present manual but also to the instruction manual from the battery manufacturer or any other manual referring to equipments used closed to a battery. Make sure you've read the caution stickers and warnings.
- 3- Do not use the BRT if connecting cables are damaged. Replace the cables before using the machine again.
- 4- If BRT is damaged for any reason, do not use it. Call the manufacturer, ask him for advises, or for repair.

Global safety care:

- 1- Make sure someone is not too far away from you when working on a lead acid battery. This person could assist you in case of problem. In general, avoid being alone when working on lead acid battery.
- 2- Make sure you have a eye cleaning kit, water and soap close to you, in case your skin, clothes or eyes get in contact with acid.
- 3- Make sure to wear glasses and appropriate clothes to work on batteries. Do not touch your eyes while working on batteries.
- 4- If your skin or clothes get in contact with acid make sure to clean immediately with clear water and soap. If acid get into your eyes, rinse them with clean water for about 10 minutes and contact your closest medical care centre.
- 5- Do not smoke; generate sparks or flames closed to batteries and BRT.
- 6- Be very careful not to drop any metallic tools on a battery. A spark, short circuit or any other electric hazard on a battery may involve an explosion.
- 7- Remove your rings, chains, bracelets, watch, or any other metallic jewel or equipment you may wear when you are working on a lead acid battery. A short circuit on a battery may generate high temperature involving metal melting and severe burns.

Before starting regeneration:

- 1- Make sure you are operating the equipment in a place where air is circulating.
- 2- Clean up the main contacts of the battery as explained here after. Beware that corrosion dust doesn't get in contact with your eyes or skin.
- 3- Make a visual check of the battery. If cracks, rack or top damages, mechanical damages, do not use the BRT.



2.7.1 Regeneration equipment

The operator must always have the following equipment at his disposal: Acid tester, ammeter, temperature gauge for batteries, connectors and discharger / analyzer equipment.

Tools shall all be electric proofed.

The acid tester is a standard device.

The ammeter shall read up to 500 Volts and below.

One can use a normal glass temperature gauge with a scale up to 65°C. Specific device dedicated to the batteries can be found on the market. An infra red temp gauge can also be used.

In order to ease the connection of different battery types, one can use intermediary cables with the most commonly used connectors you can find on forklift.

Discharger shall be able to unload a battery under a constant current for 5 hours. One should be able to set the resistance in order to get the required current.

2.7.2 Staff safety equipment

The premises shall be a restricted area where only authorized and qualified staff is allowed.

All Norma concerning electric, acid and fire risk shall be respected and implemented.

The operator shall comply with the domestic risk management involved in the regeneration arena, as well as in terms of health and care, in case several activities are processed in the same premises or in the immediate surrounding.

The staff involved in battery regeneration shall have and wear the relevant protection and equipment to proceed.

Necklace, bracelets, watches, metallic glasses shall be banned from the regeneration workshop has they may get in contact with any electric devices and generate risk for the persons and the environment.

Recommended equipments are :

- Acid resistant gloves ;
- Acid resistant talveg ;
- Safety face cover or safety glasses ;
- Eyes cleansing, extinguisher, absorption equipment etc....



Any specific safety operation rules within the premises where the regenerator is used shall be set up by the operator's management according to his own risk management.

III. **Regeneration process**

3.1 Getting ready and start up

Main safety switch shall be set on 0 position. Cables shall be disconnected from the main PSU and battery line shall also be disconnected.



3.1.1 Battery preparation

All work on the battery shall be done while it is disconnected.

While working, one should always wear safety clothes, gloves and glasses or face shield.

Battery should be cleaned and dried. Dust and liquid shall be removed from the upper part of the battery to avoid arcs or any hazardous electricity flow. This is mandatory before proceeding to the regeneration.

With a hard non metallic brush operator shall clean both + and – contacts.

Proceed to a battery visual inspection looking carefully for any mechanical or electrical failures such as, cell leak, short circuited cells or battery (while cells are not isolated from the battery rack).

- If the battery is equipped with hard bridges between the cells, attachment to the cells shall be checked. Sometime those connection can be loose (check with an isolated screwdriver) and cracks can appear avoiding the normal contact between the cells. On copper bridges blue dots and tracks can appear showing that corrosion is already in place and contact between the cells may be faulty. Those should be cleaned or replaced upon corrosion status.
- In case of cell short circuit, operator will notice a big difference on voltage compare to the other cells.

During pulsation process with the BRT, voltage can be checked on each cell, the weakest one will then be identified easily (see later).



If any of the above mentioned is noticed, the breakdowns shall be solved before starting the regeneration process.



On a battery showing short circuit failure, to proceed to regeneration may endanger the operator as high risk of explosion may occur.

3.1.2 Control and battery cells measurement

An initial test on each cell shall be conducted. All measures are collected on the “ Regeneration Test » record sheet (see appendices).

As a global rule, cells will be counted from 1 to ... starting from the + connector.

From time to time, operator should clean the cells with compressed air to ease air circulation on top of the battery. Battery is always producing small quantity of hydrogen gas when mixed to air generate oxy-hydrogen, a very ignitable gas with explosion risks.

a) Cell voltage

With an ammeter check each cell voltage starting from the + connector moving to the – one following the connections. Always proceed according to the same pattern.

Ammeter sticks shall be strongly applied on the connectors under the cell covers. Usually some holes are on the top of the cover to ease the measurements. Report all figures on the work sheet « Regeneration Test ». Voltage shall be recorded in the Volt section. Report the exact value red on the ammeter.



All measures shall be recorded at a standard temperature of 30 °C.

Above 30 °C operator should decrease voltage by 0,005 Volt every degree exceeding 30° C. The greater the temperature the higher voltage is showed on ammeter.

Ex : Voltage red at 42° C → V= 2,18V

After correction to adjust at 30°C → V=2,12V



b) Cells acid density

At an average temperature between 22 and 34 °C electrolyte density should be between 1,10 et 1,28. The highest acceptable level in a new battery is 1,32.

Check the electrolyte density in each cell with the densitometer. Remove the covers and dip the densitometer in the cell. Only pick up the liquid which is in the cell. Close the cover of the cell after each measurement. Proceed according to the same sequence you did to record the cell voltage.

Record the collected values in the « Density » section of the « Regeneration Test » worksheet. Report the exact value collected on the worksheet.

All measures shall be recorded at a standard temperature of 30 °C. Above 30 °C operator should increase density by 0,0007 every degree exceeding 30° C. The greater the temperature the lower the density is showed on densitometer.

Au dessus de 30° C on devra augmenter la densité lue de +0,0007 par degrés au dessus de 30°C.

Ex : Density at 45° C → 1,175

Density after correction adjusted to 30° C → 1,185



3.1.3 Electrolyte level control

Once electric and density test completed, it is sometime necessary to refill the level of water in the cells.(≈ 1cm above the grid)



Never proceed to electrolyte measurement after refilling the cell with distilled water. Values would be false.

Check liquid level in each cell. Complete in cells where the level is very low. (Check quantity on the battery manufacturers instruction datasheet).

In most cases, the best level is 1 cm above the electrode plaques.



**Do not connect a dry battery to the BRT.
Explosion risks are then greater.**

Dry cells are filled with distilled water. Water may have evaporated and sulphuric acid turned into lead sulphate. However, all the active materials remain in the battery. Do not add acid unless there is no more density at all and the cell has suffered over flooding while being charge at the owners place.



Sometime, no electric or short circuit can be found during the check up, however the regeneration process may have not effect on so called « disable » cells.

It may occur in situation such as :

- When cells leak and operator keep on refilling it. (Corrosion marks on the rack can be noticed);
- Over refilled cell even though it was not required. Cell gets washed up.

In both situation, sulphuric acid needed to generate current is spilled away and cell density is weakening.

In such a situation, the operator may proceed to complete the cell in adding acid for density recovery.

Report to regeneration help diagram hereafter.

Greatest care shall be taken to avoid acid contact with eyes and skin. If this shall happen, clean with still water and contact immediately the nearest medical care centre.

3.1.4 Battery(ies) connection to the BRT

Main switch should be on « 0 » (zero).

First connect the cables to the battery and second to the regenerator. Tight the cables with an isolated wrench at the manufacturers usually recommended torque (25Nm) or use quick matching connectors.



Contacts should be clean to avoid overheating or sparks that may involve contact melting, fire and explosion occurrence.

First connect the blue – (minus) cable to the – (minus) contact of the battery. Make sure the + cable is not in contact with the ground.



Second, connect the red + (plus) cable to the + (plus) contact of the battery.

If one needs to connect several batteries at the same time, they must be in series as mentioned above. Only difference is that the + contact of the first battery is connected with the – contact of the second one. If more than two batteries the same connection will be done with the others.



If several batteries are connected at once, special care shall be given to the total voltage which shall not exceed 96 Volt. Batteries connected together shall have the same voltage and the same amperage. In order to get the best results, it would be great to connect



batteries with the same background and sulphating state. (I.e. same tension on connectors).

The main switch of the BRT shall always be on ZERO. Then plug in the cable between the battery and the BRT.

Check and secure the connections. If not tight, you may get sparks which may be dangerous.

3.1.5 Temperature gauge connection and positioning

The connector for the temperature gauge is on the top right side of the regenerator.

As a basic statement, remove the cover of the middle cell of the battery and insert the temperature gage in it. Insert as deep as you can in order to get at least 1/3 of the gauge below the electrolyte level. The gauge can touch the lead plaque, it will not get any distortions effect on the temperature records.



When regenerating several batteries at once, the gauge shall be placed in the cell of the weakest battery (ie the one with the highest sulphating level).

Connect the temperature gauge to the BRT.

As a global statement, temperature gauge shall always be placed in the most sulphated cell (i.e. lowest voltage or acid density) and also in the cell that will be the less air cooled (i.e. the one on the middle of the battery).



Anyhow, during the first stage of the regeneration process, a quick voltage test shall be conducted during the pulsation process which may help to identify a weak cell needing special care. Then the temperature gauge will be place in this cell. (Check Pulse charge caper 3.2.1).



3.1.6 Plug to the main power supply

Check first that the BRT main switch is on Zero.

Then plug in the main red plug on the mid right side of the BRT.

Lift the safety cover and connect the plug.

For details about general connection please report to chapter 2.3 connecting the equipment.



3.2 Starting up the regeneration process

Main purpose of the regeneration is to make sure that the active agents of the battery which turned into chrystal will return to their original liquid status.

To reach this point the BRT will proceed to pulsation sequences up to 300 amps at the specific vibrating lead sulphate chrystal frequency. Chrystal will resound and vibration will erode it and turn it into liquid as it used to be. Along the process the plaques surface sulphation free will have greater chemical reaction withe the surrounding elctrolyte, accelerating then the process.

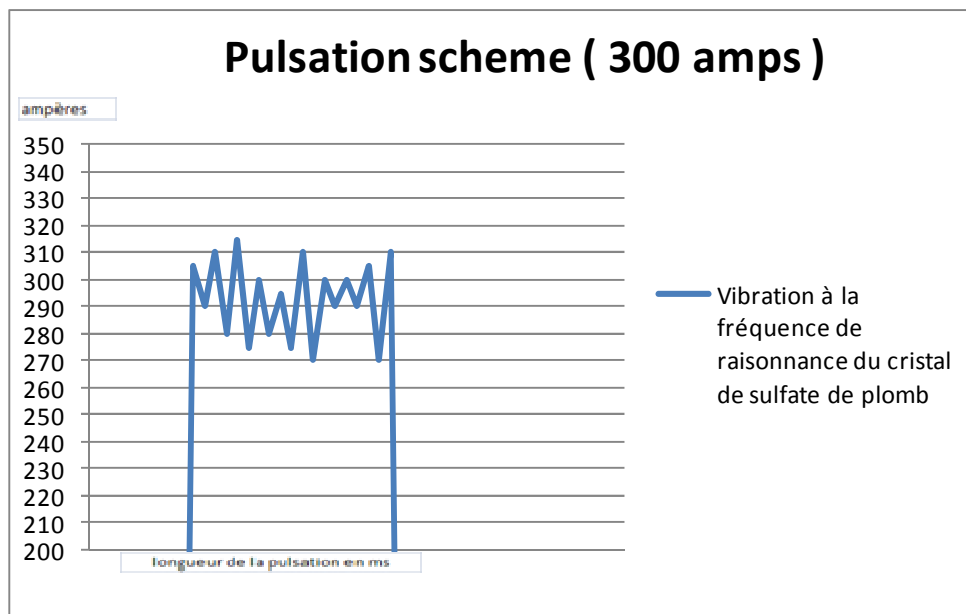

The pulsation cycles below are set to 200ms every 3 seconds in order to avoid temperatur of the cells to raise to rapidly.

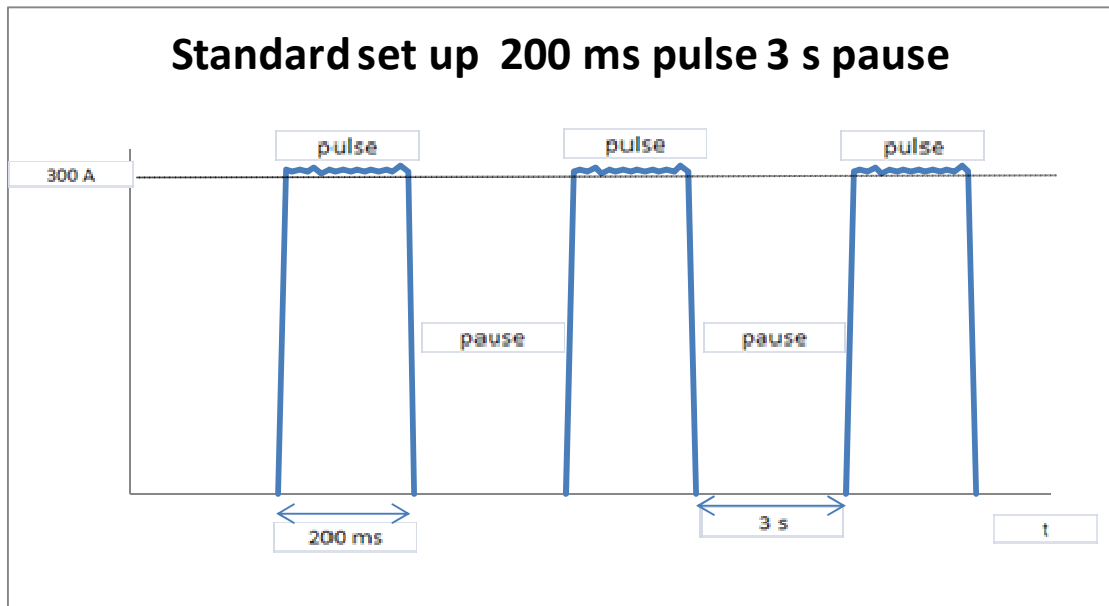

During the regeneration process, density is getting greater smoothly at the beginning and increase dramatically when reaching the end of the process. Indeed at the end of the process the remains of the lead chrystal sulphate are changed to their original active element status.

The BRT has safety device that will stop the process if some parameters are getting to high :

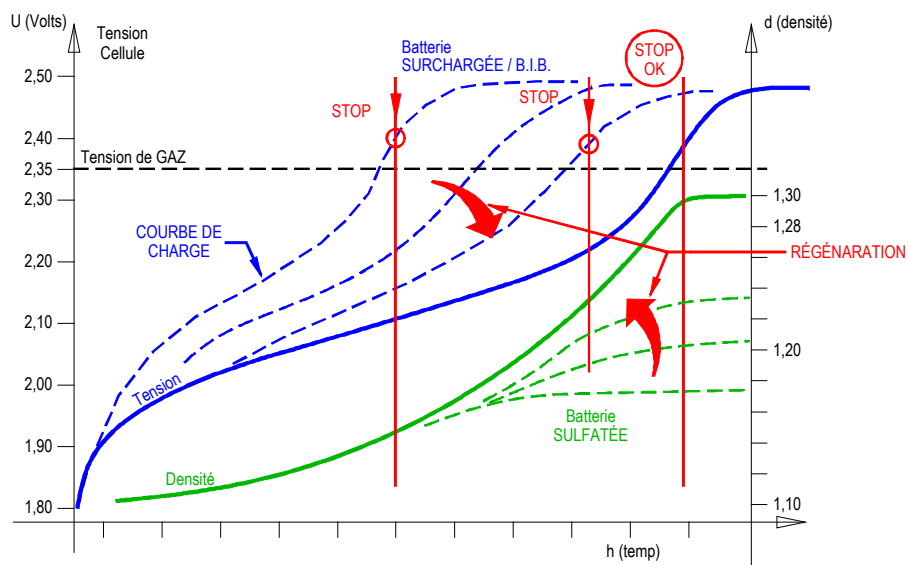

- Temp >45°C
- Voltage >2,4V per cell



The operators knowhow will then consist of reaching the best sulphation dissolution (ie no chrystal remains) :

- Monitoring and mastering the temperature height
- Monitoring the voltage increase

When the High Voltage alarm appears (2,4v during pulsation and density over 1,28) that means the regeneration is almost over and the battery shall be tested on the discharger / analyzer BDX.

At a first step: turn the main switch of the BRT on the start position.

The menu of the regenerator is divided in 3 main applications:

Manual: Manual program

Automatic: Pre set program for traction batteries

Parameters : To access to parameters of the program in use



To select an application press « OK ».
Then you can select any values or choices pressing the arrows selectors.
To validate your choice once on the display screen press « OK »
and go to the next parameter.



3.2.1 MANUAL set up

In this chapter we introduce the Manual set up which is the largest scope in terms of program possibilities. Later on the Pre set section will be described too.

Definition:

One loop is a full period of time including pulsation period followed by a constant charge period.

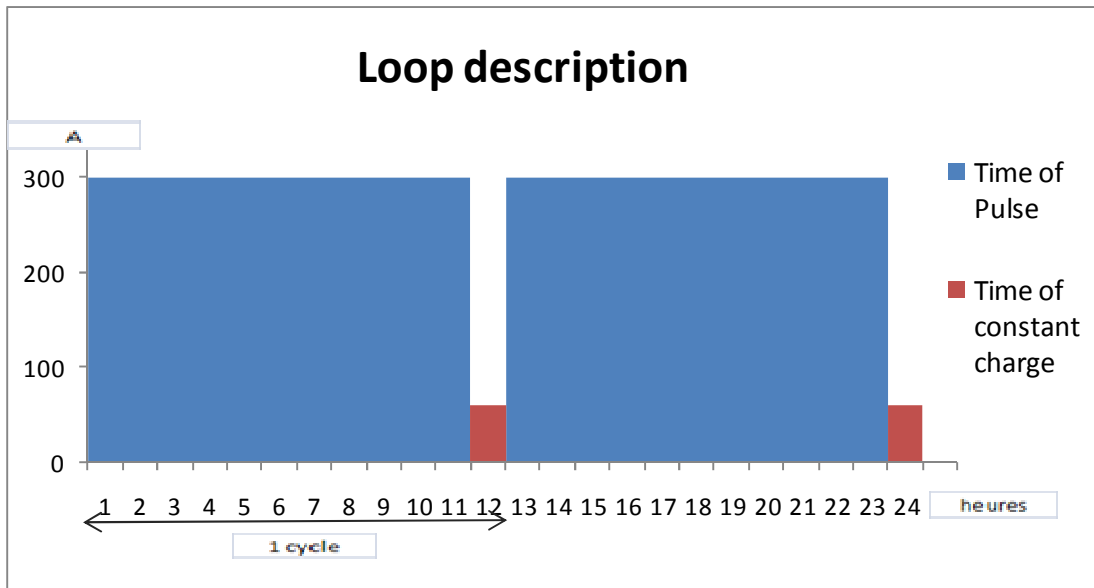

A phase is a number of loops.

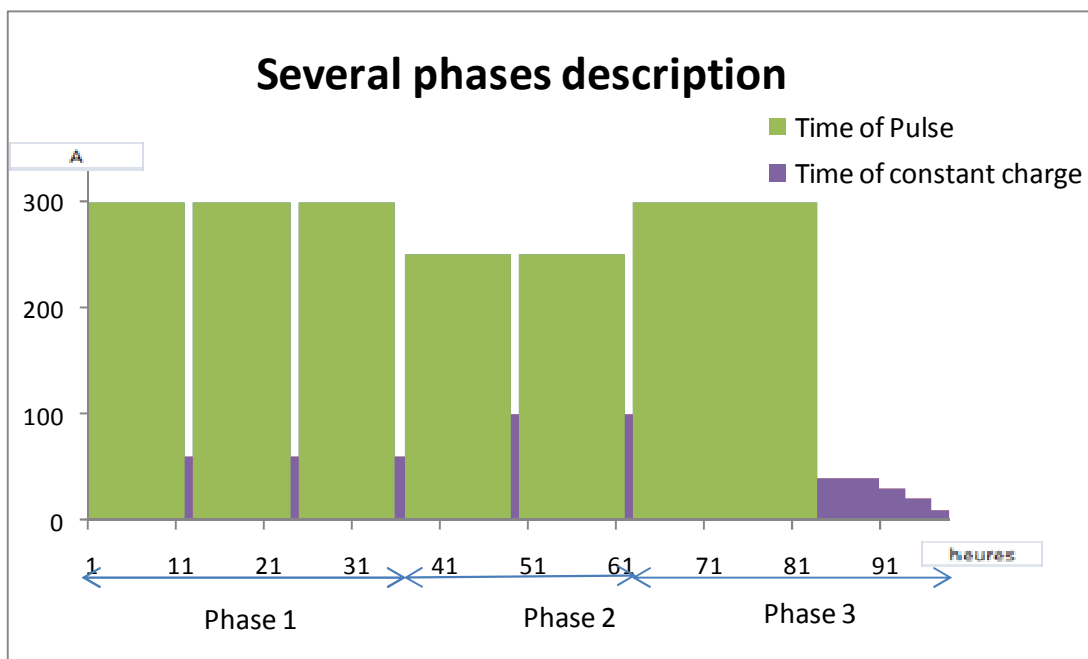

Manual program :

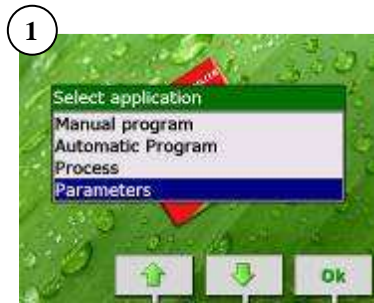

press « Select application »,
Go to Manual.



Set battery voltage



Set battery AH
Enter 0 if not mentioned

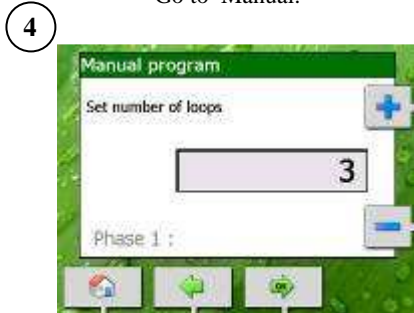

Set number of loop (1 to 50) One loop
includes pulse and constant charge period



Set pulse duration (0 to 24 hours)



Set pulse lenght in milliseconds
(80 to 500 ms)

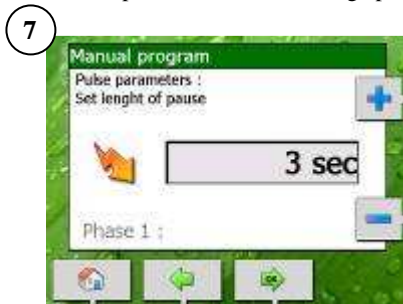

Set pause lenght (1 to 7 seconds)

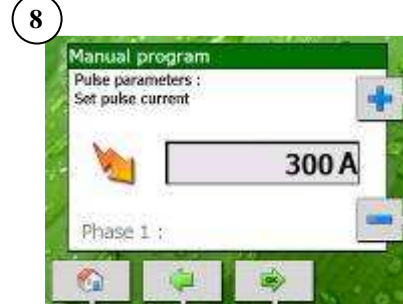

Set pulse current in Amp (0 to 400 A)

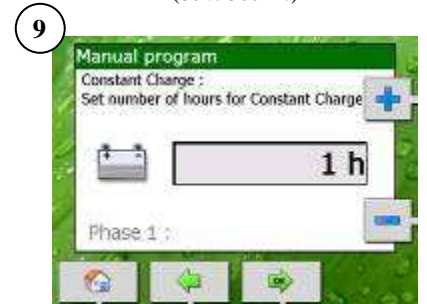

Set constant charge duration
(0 to 24 hours)

Note: Standard current used for traction batteries is 300A. Processing with a lower current, 250 A, allows to decrease the electric consumption of the BRT, to reduce the temperature picks risks, but it will required a greater number of loops.



Beware that for starting batteries, current setting shall be limited to 45 A for car batteries and 90 A for Lorries and buses.

If pulses are too long cells may reach temperature highs. A good setting of pauses between the pulses will help mastering temperatures and current.

If battery Ah has been set previously, adjustment can be done either in % of capacity or a current fixed limit.



If « % Ah » is selected, constant charge current limit will be adjusted between 5% and 25% of the battery capacity.



If « Courant » is selected constant charge current shall be manually adjusted between 0 and 120 A or « 2.4V imposed ».
 If « 2.4V imposed » is selected, charge will be done via equalisation of charge at 2.4 V per cell.

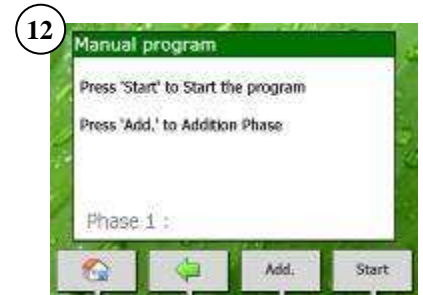
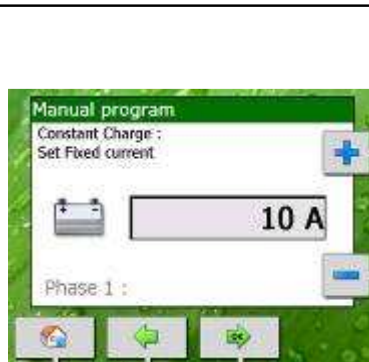
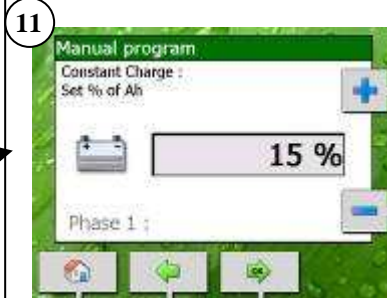

One or several phases can be added. Select « add ». If selected, setting will start again from the « set number of loops » section. 1 to 3 phases can be input. If no phases to be added, simply press « start » to initiate the process.



During the regeneration process, the operator shall control every day the water in the cells and adjust to the appropriate level.

a) Charge by pulse

Regeneration by pulsation, screen display:

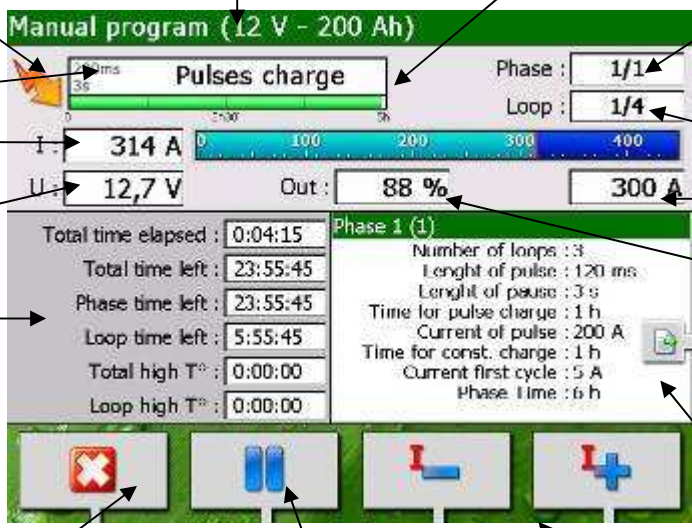

The screenshot shows a control interface for a 'Manual program (12 V - 200 Ah)'. It features a 'Pulses charge' section with a pulse gauge, current (I: 314 A) and voltage (U: 12,7 V) readouts, and an 'Out: 88%' indicator. A 'Phase 1 (1)' information box displays settings like pulse length (120 ms) and current (200 A). At the bottom, there are control buttons for stop, pause/play, and adjusting pulse intensity (I- and I+).

Annotations for the interface elements:

- Animated signal showing the pulse sequence.
- Shows type of program selected and battery type.
- Shows type of loop selected with a pulse gauge for the remaining pulse time. Display pulse and pause set up.
- Phase in process / Total number of phases.
- Loop in process/ Total number of loops.
- Set intensity.
- Thyristors opening stage. Red flashing screen appear if reaching 100%
- Info on the phase in process. If you press on the display you see for a short period information on the remaining phases and if temperature or voltage alarm occurred.
- Displays I+ and I- : Can set the amperage of the pulse highs. New set up will smoothly be in place. Operator can keep control
- Pause/Play display. If pressed, regeneration process will be on pause mode. Operator can work safely on the battery.
- Stop display, if pressed you'll have to confirm your command before the stop order will be executed.
- Total elapsed time and total remaining time.
- Battery current gauge.
- Instant achieved intensity.
- Current parameters taking into account the T° default if any.

Pulse are set to increase intensity smoothly over 2 minutes to reach set level, in order not to damage the battery. 1 to 3 minutes may elapsed till pulses get stabilized sometime. One may notice some difference between pulses that may go from 10 to 20%. Those variations are normal and may be even greater at the beginning of the regeneration process during the first loop. Those variations disappear smoothly to reach the set value.



During the process, amperage of the pulse highs can be adjusted. One shall simultaneously press on « I+ or I- » buttons and on the upper right button. The new order will smoothly be executed over the two minutes onwards.
Caution: The modification will only apply to the phase on course and will resume the initial settings at the following phase.



This thyristors value shall remain between 50 and 98 %.

If you read 100% it is a failure alarm (report to chapter 4.5.4 hereafter).

After a few minutes of pulsation, once nominal amperage is stabilized, it is recommended to check voltage of each cell or of the battery if it is a sealed item. Tension may reach 3 Volts + or – 1 volt PER CELL during pulsation which is normal.

If tension reach 5 or 6 volts per cell during pulsation you may be facing the following problems :

- ✓ Cell is more sulphated than the others ;
- ✓ Cell might have been short in water during its operation ;
- ✓ Cell is not the same quality as the other ones ;
- ✓ There is a possible short circuit.



In this situation, the temperature gauge shall be placed in this cell as it may be more sensitive to high temperature. This will help to protect the battery and secure the process.

b) Constant charge

Constant charge screen display :

Animated signal showing the constant charge sequence.

Type of cycle in process, and gauge for the remaining constant charge time .

If fixed current or AH % has been selected for the first cycle, screen displays the intensity in process; if « 2.4V imposed » has been selected, Max targeted charging intensity will be displayed.



When a regeneration phase includes several loops, the constant charge is as follows:

- At first, amperage is locked at a % of Ah current or at a preset value (see display 10 and 11 on previous pages), and this will last during a period of 30% of the number of total loops set. This value shall be between 10 and 15% of the battery capacity in order to keep pressure on the current value pulsed in the battery..
- Then the amperage is set automatically by the BRT to reach 2.4 V per cell. Charge is then so called “free charge”. Constant charge is applied to the battery in order to proceed to equalization in each cell to reach 2.4 V per cell. Amperage is automatically set by the BRT upon the intra resistance of the battery at the end of the pulse loops, to reach 2.4 V. No manual setting can be done.



It is then very important to check that the number of set loops is sufficient to make sure that, when the BRT switches to free charge, imposed current shall not be too high.

For specific situation, when voltage is below 1,7 volts per cell, you should report to the specific procedures described later on in this service manual. Procedure shall be adapted whether the weakness is on one cell, several or all of them.

c) Automatic program

Automatic program:

Select « automatic program » from the main menu.
Three programs are displayed :

- Traction battery program
- Starting battery program
- Stationary battery program





3.2.2 Automatic program for traction batteries

To ease the operators' procedure, the BRT has already some pre set programs ready to use.

You can access to those programs in the menu at the « **set application** » page.

Operator can work on three main treatments:

- Preventive regeneration 24h :
 To be applied when you have annual maintenance contract with the battery owner. It keeps the battery at its greatest capacity, as new, on the long run.
 Loops are short and scheduled to treat and deliver a charged battery in 24 hours in order to keep the forlfts production pace.
- Curative regeneration 72 h:
 This mode is for 4 to 6 years batteries. Treatment last for 72 hours. It aims at removing sulphation and increase current.
- Full curative regeneration 96 h :
 This mode is for batteries over 6 years old. This is a deep treatment to remove all the sulphation from the plaques and give the battery a second life frame.
 To be efficient, this process requires 96h of treatment, which means 8 loops of 12h.

Standard settings are as follows:

Preventive regeneration 24 h :

Parameters	Unit	Phase 1
Pulse intensity	Amp.	300 A*
Pulse lenght	mSec	200 ms
Pause	Sec	3 sec
Number of cycles	Number	4
Pulse duration	Hours	5 h
Constant charge duration	Hours	1 h
Constant charge current	% Ah	15 %
Total time :	Hours	24 h

Curative regeneration 72 h :

Parameters	Unit	Phase 1	Phase 2
Pulse intensity	Amp.	300 A	300 A
Pulse lenght	mSec	200 ms	80 ms
Pause	Sec	3 sec	2 sec
Number of cycles	Number	4	1
Pulse duration	Hours	11 h	22 h
Constant charge duration	Hours	1 h	2 h
Constant charge current	% Ah	10 %	2.4 V imp.
Total phase time:	Hours	48 h	24 h
Total time :	Hours	72 h	

Curative regeneration 96 h :

Parameters	Unit	Phase 1
Pulse intensity	Amp.	300 A
Pulse lenght	mSec	200 ms
Pause	Sec	3 sec
Number of cycles	Number	8
Pulse duration	Hours	11 h
Constant charge duration	Hours	1 h
Constant charge current	% Ah	10 %
Total time :	Hours	96 h



*Note that in those programmes pulsation amperage is set at 300A. However, for the small sealed traction batteries (golf carts, cleaning machines) it is recommended to set a limit at 200 A in order to get a better control over temperature and voltage.



During the process, amperage of the pulse highs can be adjusted. One shall simultaneously press on « I+ or I- » buttons and on the upper right button. The new order will smoothly be executed over the two minutes onwards.

Traction battery program :

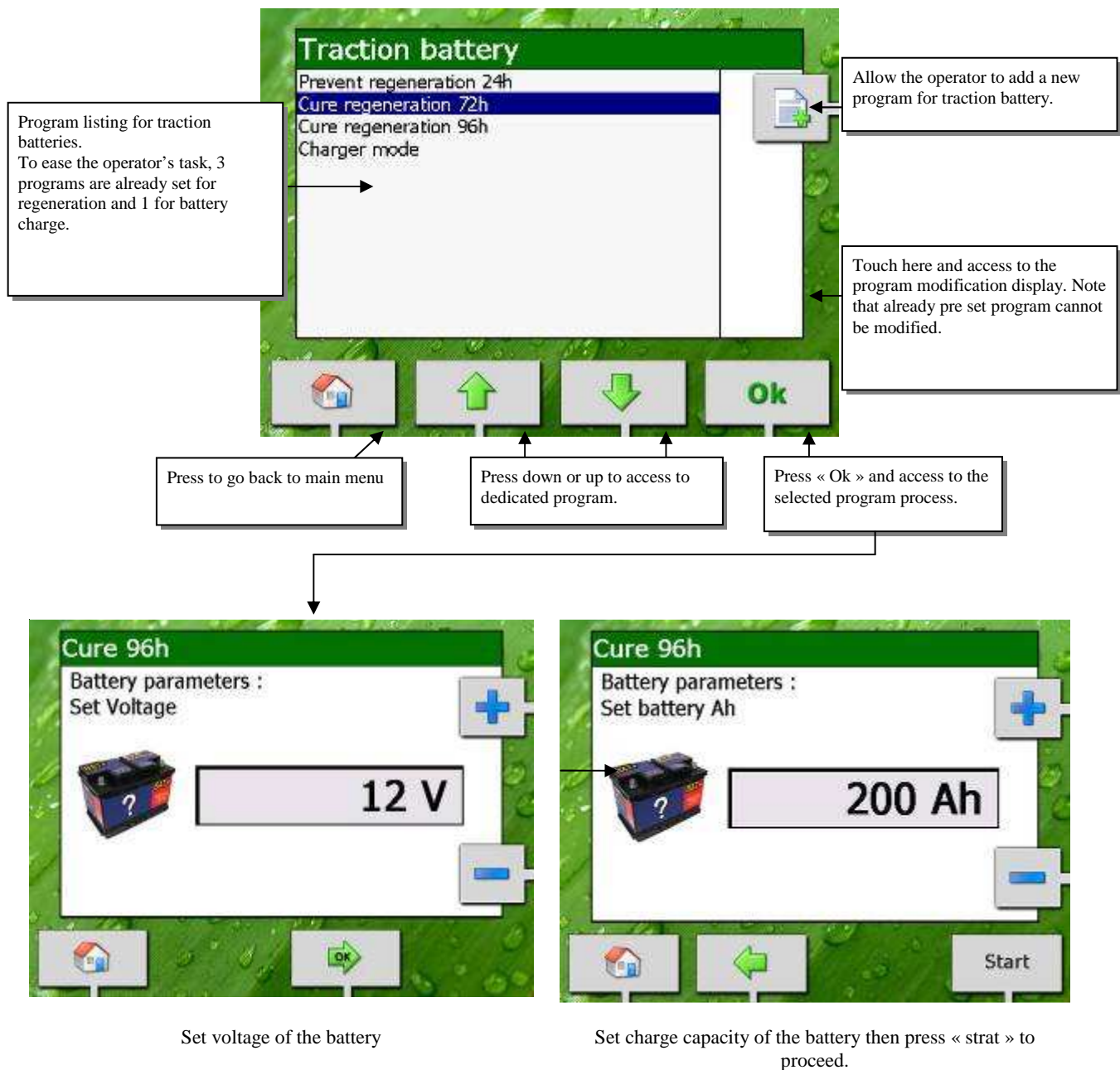



3.2.3 START mode dedicated to 12 V starting batteries

Starting batteries shall be treated at a lower intensity than the traction or stationary ones as the plaques are thinner and the starting batteries globally weaker than the biggest ones.

As the BRT can proceed with intensity up to 400 A, it is recommended to set up several battery parallel lines taking care of the intensity dispatch on each line.

Starting batteries regeneration Getting connected

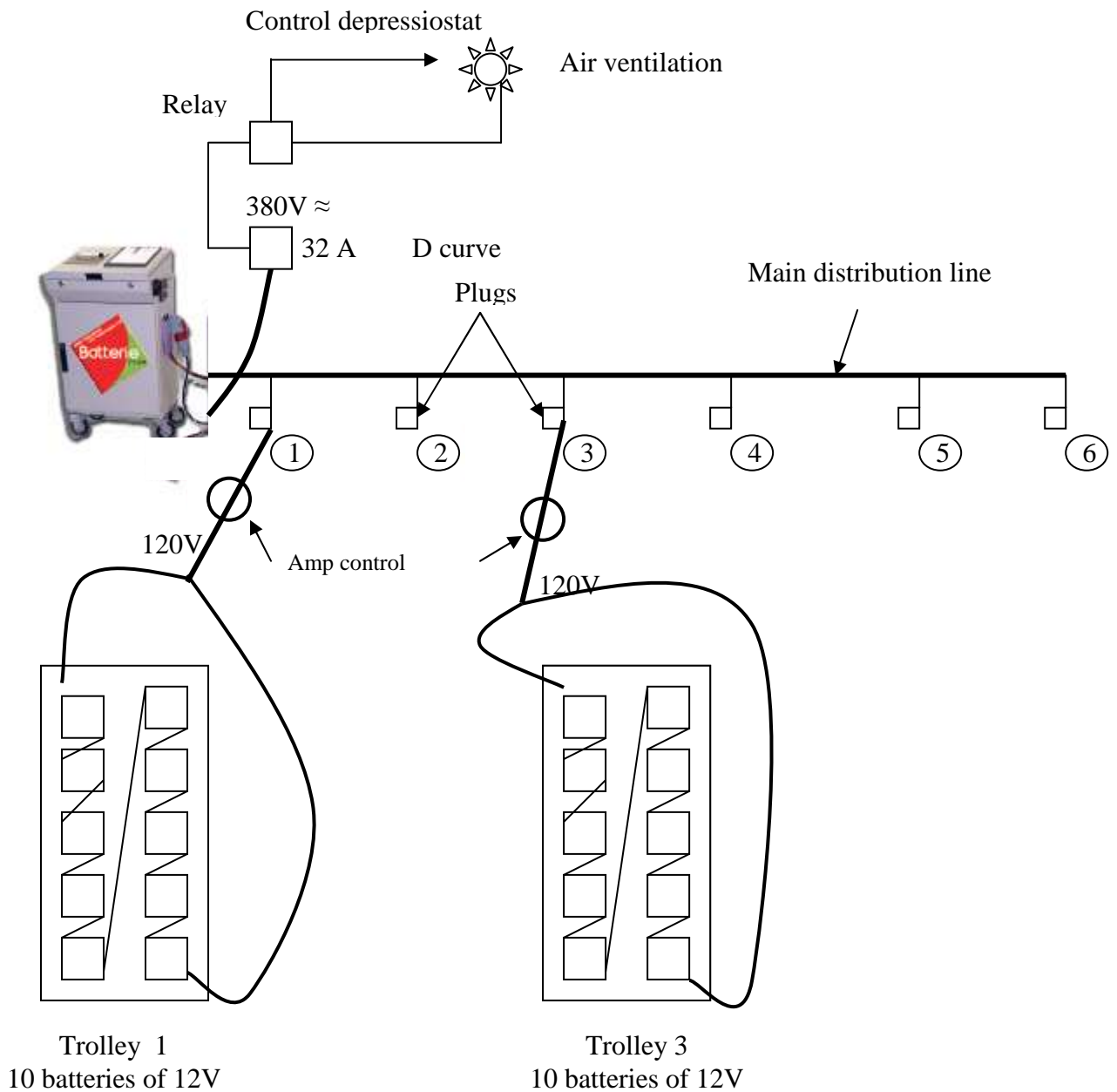



Caution :When batteries are in series you have to add the tension. Maximum tension shall not exceed 120v (ie 10 batteries of 12v). Over 120 volts it is consider as risky for the operator health.

When connecting the batteries, special attention shall be drawn not to make a full connection ring, otherwise shortcircuits will occur and the risk for fire and explosion will be high.

In order to avoid mistakes, it is recommended to follow the procedure below:

Connecting procedure

- 1- Positionning and lining up the batteries on a trolley
- 2- Connect batteries in opposition line in order to keep clearance between two main connectors (+ / -)
- 3- Connect both (+ / -) to the main distribution line.
- 4- Connect all the batteries in series
- 5- Start the BRT
- 6- Amps control on each line.



Starting batteries regeneration process

Starting batteries requires a well organized set up in the workshop to ease the work and ensure safety.

Indeed, as the starting battery cost is far lower than the traction and or stationary ones, starting batteries regeneration process requires to work on high volume.

Select the batteries

Operator should test the capacity of the batteries :
Look for short circuits (tension below 10v) ;
Look for failures (Drop on the starting test bench) ;
Check the global aspect of the batteries.

To proceed to those tests, it is recommended to use a Mechanical tester with a needle, more efficient than the Analogical ones.



Testing

The operator should avoid to many manipulation, so that the workshop shall be well organized. He would have first to clean and identify with stickers all batteries. Then he will measure tension and density of the electrolyte.

With trolleys and baring tables such operation will be faster and safety will be preserved.



Positioning on trolleys.



Connecting the batteries



Regeneration in progress



Caution : the above procedure shall be followed in order to avoid short circuits in respect with operators safety. All connectors shall be adapted (100A pliers, lead connectors or jump).

All lines in parallel must all have the same tension (voltage).

The temperature gauge will be placed in the electrolyte of the weakest battery or in the centre cells of one of the batteries.

When connecting the batteries it is important:

- Not mixing type of batteries, truck and cars do not mix
- For each battery type, mix the lines to get an average capacity about the same per line.
- Do not set up parallel lines with good and very weak batteries, otherwise, the treatment will benefit to the weakest one but not to the other.





12 V starting batteries program :

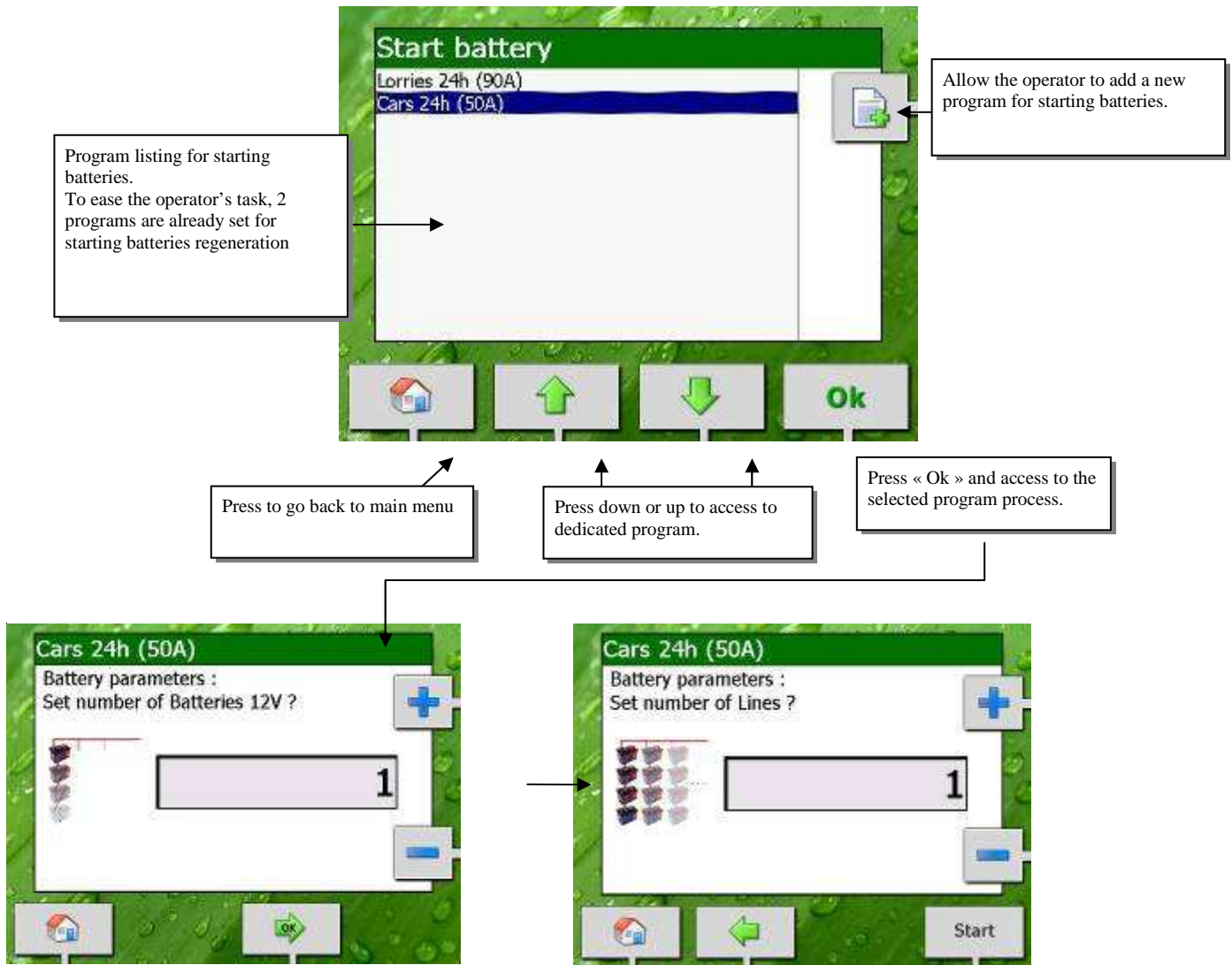

Set number of battery per line. This setting will determine the current to be processed which is not the total number of batteries.

Set the number of parallel lines. It is mandatory that all lines have the same global current. Press « start » when ready to proceed.

Pre settings for the 12 V starting batteries are as follows:

Lorries 24 h :

Parameters	Unit	Phase 1
Pulse intensity	Amp.	90 A
Pulse lenght	mSec	300 ms
Pause	Sec	3 sec
Number of cycles	Number	4
Pulse duration	Hours	5 h
Constant charge duration	Hours	1 h
Constant charge current	% Ah	10 A
Total time :	Hours	24 h

Cars 24 h :

Parameters	Unit	Phase 1
Pulse intensity	Amp.	45 A
Pulse lenght	mSec	300 ms
Pause	Sec	3 sec
Number of cycles	Number	4
Pulse duration	Hours	5 h
Constant charge duration	Hours	1 h
Constant charge current	% Ah	10 A
Total time :	Hours	24 h



Batteries shall be gathered and regenerated within the same scope of capacity, current and age.
Do not mix car and Lorrie batteries.
All lines shall be balanced and with the same total voltage.

Check the current balance at the beginning of the regeneration phase.



Constant charge session starts and last for 10 minutes. This time frame shall be used to control the current balance on each line..
The current balance shall be balanced with a frame tolerance of 10 %.
If balance is not reached, press the stop button. Dispatch the batteries in a new order to reach the greatest balance.

After 10 minutes, the program will start.



During the process, amperage of the pulse highs can be adjusted. One shall simultaneously press on « I+ or I- » buttons and on the upper right button. The new order will smoothly be executed over the two minutes onwards.

Qualification of the battery

The real capacity of the batteries is measures with an analogical starting tester. The electrolyte density is considered as good from 1,26 (i.e., a little lower than the traction batteries)



Dismantling the lines

After regeneration is over, lines should be dismantled. This operation shall be conducted with the greatest care to avoid short circuits as the batteries are now fully charged.

General rules

Regeneration parameters for truck batteries :

Pulsation : 90A

4 loops for 6h (5h pulsations, 1h constant charge)

Maximum capacity of the BRT 40 batteries within 24h.

Regeneration parameters for car batteries:

Pulsation: 45A

4 loops for 6h (5h pulsations, 1h constant charge)

Maximum capacity of the BRT 80 to 100 batteries within 24h.



3.2.4 STATIONARY BATTERIES

Stationary batteries are constantly kept in floating charge.
Thus, there are often always fully charged and must go on the discharger before being regenerated on the BRT.

Stationary batteries with tubular plaques and liquid electrolyte will be treated the same way we do for traction batteries. (Report to previous chapter).

Stationary batteries sealed AGM shall be treated in series such as we do with the starting batteries in order to get a better profitability as those batteries may need high volumes for a good ROI.

Those batteries are subject to tension memory, so that it is requested to discharge the battery prior to any regeneration. Then it is recommended to set up battery line which maximum voltage will suit the discharger analyzer used by the workshop. Usually most discharger have a cap at 96v.



The temperature gauge shall be placed between two batteries close to each other if they are gel or AGM.

Stationary batteries program :

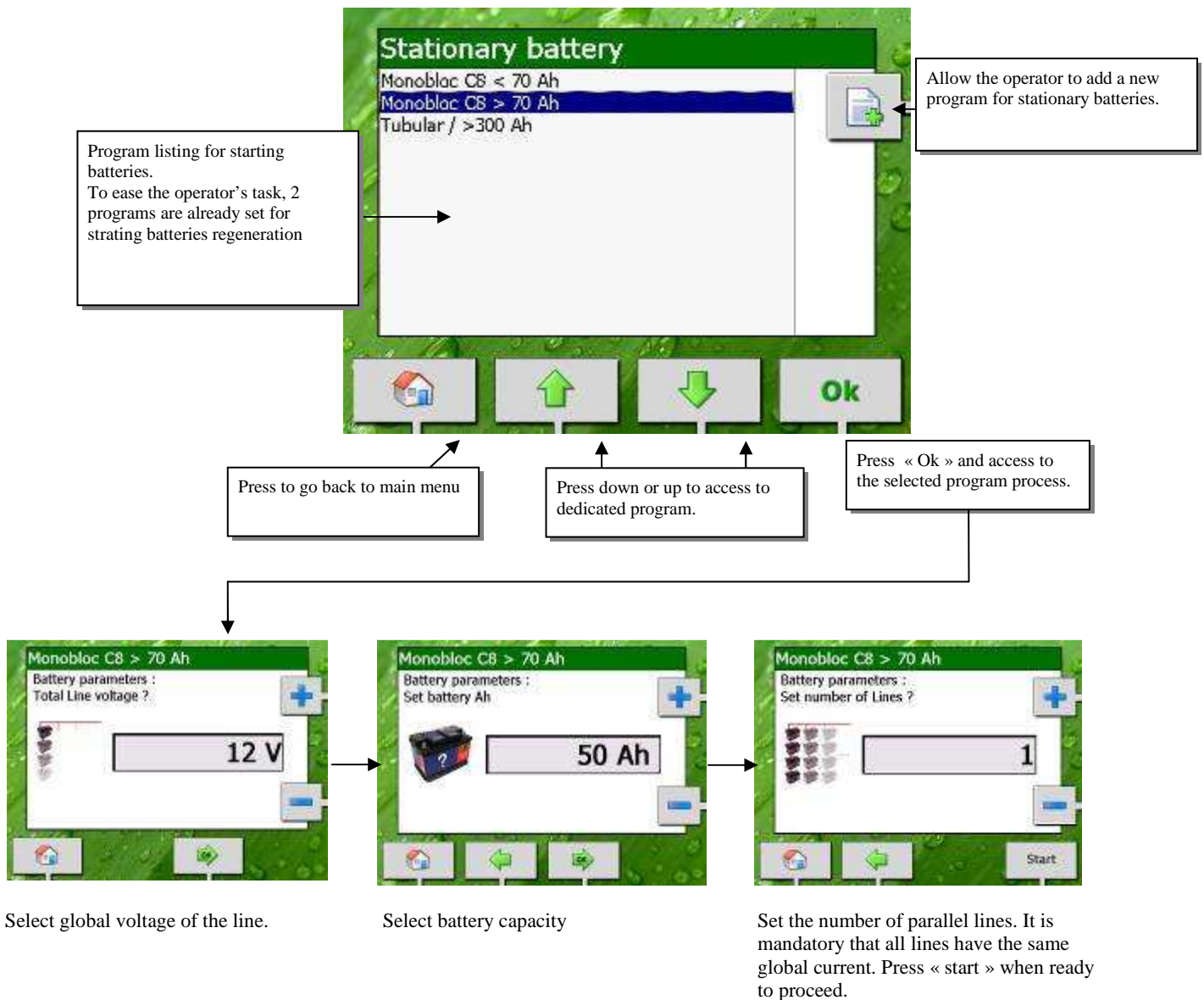

Pre settings for the stationary batteries are as follows:

Parameters	Unit	Monobloc C8 < 70 Ah	Monobloc C8 > 70 Ah	Tubular ou > 300Ah
Pulse intensity	Amp.	100% de C8	200 A	300 A
Pulse lenght	mSec	500 ms	120 ms	200 ms
Pause	Sec	1 sec	3 sec	3 sec
Number of cycles	Number	1	3	4
Pulse duration	Hours	23 h	7 h	11 h
Constant charge duration	Hours	1 h	1 h	1 h
Constant charge current	% Ah	10 %	10 %	10 %
Total time :	Hours	24 h	24 h	48 h



During the process, amperage of the pulse highs can be adjusted. One shall simultaneously press on « I+ or I- » buttons and on the upper right button. The new order will smoothly be executed over the two minutes onwards.

After being regenerated, those batteries have to go on floating charge. Stabilization will be at 2.35V per cell, up to 0.5A residual flow.

Regeneration is adjusted in order to avoid quick increase of tension, that means that at the end of the process the battery charge may not be completed.

TREATMENT PROCESS

- Reception of the battery and analysis (Shape of rack and connectors, voltage over or at the nominal value)
- Check and fill the cells with distilled water for lead batteries.
- Set up series line to discharge the batteries on the BDX discharger analyzer.
- If already discharged, battery can go on BRT directly
- Several parallel lines can be treated simultaneously. Check the current balance on each line setting up a short constant charge loop at 10A (Report to starting battery chapter)
- Set the requested standard loops.
- CAUTION IF YOU HAVE TWO LINES OF 96V IN PARALLEL AND YOU WANT TO TREAT THOSE AT 50A IN PULSATION? YOUR PROGRAM SHOULD BE ON $50 + 50 = 100A$. Same calculation apply for constant charge to be set at twice the value of the requested treatment.
- Set up the floating charge stabilized at 0.5A and 2.34V per cell.
- Check on the BDX discharger the results under C_1 , C_3 , C_8 ... as per the battery criteria.



Caution : When batteries are set in series, tension will be added. Maximum tension shall not exceed 120v (ie 10 batteries of 12v each). Over 120 volts, there is physical risk for the operator.

When connecting the batteries in series, take care not to close the pattern which may involve short circuits, thus explosion and fire risk may occur.

ISOLATED TOOLS SHALL BE USED BY THE OPERATOR AS PER STAFF SAFETY REGULATION



3.2.5 MODIFYING OR SETTING UP A NEW PROGRAM

Operator can set up and/or modify programs.

Add a new traction or starting battery program:



In the traction or starting program select  then enter the name of the new program (minimum 3 letters)).

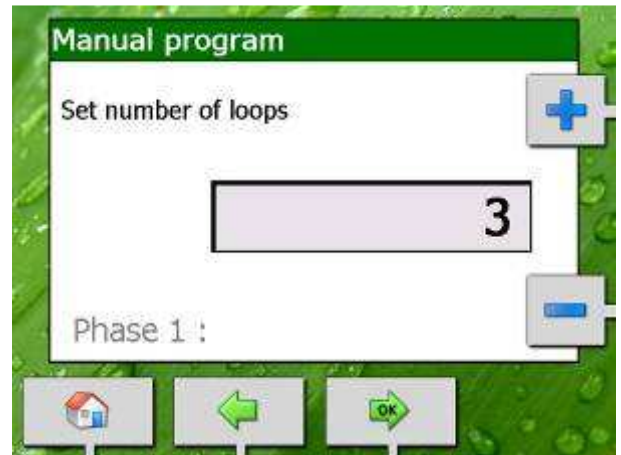

Once named, proceed to the parameters setting starting from the set number of loops phase 1.

Modify a program:

In the Traction or starting menu, select the program to be modified pressing the  display, the following display will show up :



3.2.6 Normal charge

The BRT can also be used as a normal charger. 3 phases maximum can be programmed.

Usually, one should check the battery capacity in Ah stamped on the battery.

A first phase will be set in order to reach the stabilization or equalization of the cell tension at 2,4 Volt : the so called « gas tension »

In the second phase the BRT will chose freely the current.

In phase 2, the amperage will slowly decrease automatically every 10 A till reaching 10 A which is the minimum maintenance charge level.

Charge will then be completed.

Check the following set up table below :

Charge mode with capacity < 700 Ah:

<i>Parameters</i>	<i>Unit</i>	<i>Phase 1</i>	<i>Phase 2</i>
<i>Pulse intensity</i>	<i>Amp.</i>	-	-
<i>Pulse lenght</i>	<i>mSec</i>	-	-
<i>Pause</i>	<i>Sec</i>	-	-
<i>Number of cycles</i>	<i>Number</i>	1	1
<i>Pulse duration</i>	<i>Hours</i>	0 h	0 h
<i>Constant charge duration</i>	<i>Hours</i>	5 h	5 h
<i>Constant charge current</i>	<i>% Ah</i>	15 %	2.4 V imp.
<i>Total phase time :</i>	<i>Hours</i>	5 h	5 h
<i>Total time :</i>	<i>Hours</i>	10 h	

Charge mode with capacity >= 700 Ah:

<i>Paramètres</i>	<i>Unit</i>	<i>Phase 1</i>	<i>Phase 2</i>
<i>Pulse intensity</i>	<i>Amp.</i>	-	-
<i>Pulse lenght</i>	<i>mSec</i>	-	-
<i>Pause</i>	<i>Sec</i>	-	-
<i>Number of cycles</i>	<i>Number</i>	1	1
<i>Pulse duration</i>	<i>Hours</i>	0 h	0 h
<i>Constant charge duration</i>	<i>Hours</i>	8 h	8 h
<i>Constant charge current</i>	<i>% Ah</i>	10 %	2.4 V imp.
<i>Total phase time :</i>	<i>Hours</i>	8 h	8 h
<i>Total time :</i>	<i>Hours</i>	16 h	

Caution: As “2.4 V impose” has been chosen during the 2nd phase, constant charge current will determined by the machine during the process to reach 2.4 V per cell.
If duration or amperage of the 1st phase are too low, set up current may be very high involving high temperature and even disruption of the main fuse in the machine.
Special care is mandatory in the choice of the battery capacity input.





3.3 Control and regeneration acknowledgment

3.3.1 High temperature

High temperature warning :

Warning signal with red flashing report.

Shows number of warning detected during the cycle in process.

Total time high temp and time elapsed during the cycle on red font as a warning signal.

If battery temperature is getting to high (over 45°C), The BRT will stop automatically for 30 minutes, to allow the battery to cool down.

« High temperature » will appear on screen. Once the temperature recovers normal level, the BRT will resume the process. BRT will set the requested parameters automatically in order to reduce high temperature pics again. Parameters will be as follows:

- During pulse session: pulse length reduced by 20% automatically, down to 80ms if needed. Below this figure, then the pause length will be increased by 1 second.
- In imposed constant charge phase: Current will be decreased by 30% down to 10A minimum.
- During free charge: As self regulation in current will apply; only stops of the charge shall occur during the process.

AFTER 4TH STOP THE MACHINE WILL NOT RESUME PROCESS



It is very important not to stop the process of the BRT; operator shall leave the machine to run the full program.

Values will automatically be set as initially requested for the following loops.
 Temperature may also be reduced by setting up manually parameters: reduce length of pulsation, increase the pause lap.

To keep temperature cool, air vent or cooling system shall be implemented.
 When a temperature failure occurs, a temp gauge will be displayed on the screen.



Caution : Exceeding temperature may cause severe damages to the battery that may destroy it. It is important to check as follows that the temperature gauge is working well.

Once operator notice there is a rotten egg smell in the workshop, it means temperature reach 60 °C. At this stage battery produces Sulphuric hydrogen (H₂S). This gas is toxic and explodes.

3.3.2 « High voltage »

High voltage warning :

Warning signal with red flashing report.

Shows number of warning detected during the cycle in process.

I : 9 A U : 15,1 V Out : 0 % 300 A

Phase : 1/2 Loop : 1/3

Total time elapsed : 0:00:05 Total time left : 26:59:55

Phase time left : 14:59:55 Loop time left : 4:59:55

Total high T° : 0:00:00 Loop high T° : 0:00:00

Phase 1 (1)
 Number of loops : 3
 Length of pulse : 120 ms
 Length of pause : 3 s
 Time for pulse charge : 1 h
 Current of pulse : 200 A
 Time for const. charge : 1 h
 Current first cycle : 5 A
 Phase Time : 6 h



This warning appears when tension exceeds the maximum eligible tension (2, 4 Volts per cell), involving then gas production. This signal is a notice showing that regeneration process may be finished. Machine will then stop automatically for 10 minutes to get voltage decreased.

BRT will set the requested parameters automatically in order to reduce voltage in the battery. Parameters will be as follows:

- During pulse session: pulse length reduced by 20% automatically, down to 80ms if needed. Below this figure, then the pause length will be increased by 1 second.
- In imposed constant charge phase: Current will be decreased by 30% down to 10A minimum.
- During free charge: As self regulation in current will apply; only stops of the charge shall occur during the process.

AFTER 4TH STOP THE MACHINE WILL NOT RESUME PROCESS

That can also mean that a cell may be damaged. Some lead particles may then be floating in the cell generating short circuits.

If so, operator will notice an excess of tension in the other cells and current will increase. Sometime the damage cell may produce gas and some noise will come out from this cell.

To cure this, check that all other cells are in good state taking tension measures during constant charge and looking for high voltage. It is recommended to regularly check cell tension during the regeneration process.

3.3.3 End of regeneration loops

When regeneration is over, « finished » appears on the screen. Operator should check the battery and upon result it should be decided whether a new phase is needed or not.



During constant charge, Regeneration will stop if the BRT notice that the battery global tension doesn't need more charge. « STOP High voltage » appears on the screen (report to previous chapter).

Operator will give a quick check on the battery.

3.3.4 Control on the discharger analyzer for acknowledgment

Mainly for traction batteries, the discharging test is mandatory to validate the C5 (5hours test). This is part of the final quality control of the whole process.

For other batteries operator shall refer to manufacturers charts.

Stationary batteries are usually tested in the C₁, C₃ or C₈ table charts.



Discharging test shall also be adapted to the use of the battery the owner is supposed to do.

For Traction batteries :

The five hours test shall be conducted :

This is an international chart requesting that battery should hold a discharge during 5 hours with a discharged down limit of 1.7 Volt per cell.

As a statement, because we are working on used batteries, test shall be conducted over 5 hours at 80% of the nominal capacity of the battery.

If battery capacity is 850 Ah, the discharge shall be conducted as follows $(850 \times 80\%) / 5 = 136A$.
Battery shall deliver 136A during 5 hours.

After 5 hours of discharge, the cut off voltage on each cell shall be over 1,7 V.

For a 48 V battery, it means $24 \times 1,7 = 40,8 V$.

A well regenerated battery would be qualified if it can hold 4,5 hours on the discharger. Indeed, once in operation again the battery will gain value after several charge cycles.

Operator shall take into account how the battery is operated by the client.

3.3.5 Regeneration control on electrolyte and voltage

In order to get correct values, measurements shall be conducted when the battery is disconnected, at least 30 minutes after the regeneration process is over.

Tension on connectors can be checked during the pause along the regeneration process.

At the end of the regeneration process it is recommended to check tension and electrolyte density in each cell. Sometime it may be necessary to change some parameters of the BRT as the battery sulphating is reducing.



With the electrolyte, if the density fell below the standard level, it is required to add some distilled water in the cell.

Measure shall be conducted before adding the water; otherwise the density value will be false as dissolution of acid will occur when adding water. If operator misses this part, it would then be recommended to do a quick constant charge in order to mix electrolyte.

A battery which is not in a good shape will often lose steam during regeneration process. So it is important to check electrolyte level after the process..

All measurement shall be conducted or converted at the standard temperature: 30°C.



Above 30 °C operator should decrease voltage by 0,005 Volt every degree exceeding 30° C. The greater the temperature the higher voltage is showed on ammeter.

Ex: Voltage red at 42° C → V= 2,18V
After correction to adjust at 30°C → V=2,12V

Above 30 °C operator should increase density by 0,0007 every degree exceeding 30° C. The greater the temperature the lower the density is showed on densitometer.

Ex: Density at 45° C → 1,175
Density after correction adjusted to 30° C → 1,185

At a usual continental temperature (20 °C), battery regeneration is over when the electrolyte density is between 1,27 and 1,3 per cell and when tension is between 2,1 et 2,3 volts per cell. Those values are reached almost everytime.

To check whether the battery is completed, those values are important but not enough, and the 5 hours discharge test shall be conducted. As a statement, because we are working on used batteries, test shall be conducted aver 5 hours at 80 % of the nominal capacity of the battery.

If battery capacity is 850 Ah, the discharge shall be conducted as follows $(850 \times 80\%) / 5 = 136A$. Battery shall deliver 136A during 5 hours.

After 5 hours of discharge, the cut off voltage on each cell shall be over 1,7 V.

A well regenerated battery will be noticed when during the first two hours of discharge both tension and electrolyte density values are not changing. Every hour operator shall check global tension and cell tension. Doing this allow the operator to see if one cell is weaker than the other and can proceed to its removal and replacement.

If new regeneration is needed, then disconnect the cable from the discharge and connect it to the BRT for a new adapted regeneration process.

Record in the « regeneration test » worksheet the final value for the electrolyte density and the battery tension.

3.3.6 Disconnecting the battery

Before disconnecting the battery, the process shall be terminated and the BRT switch off on zero position.

If regeneration process is finished, main BRT switch will be on zero.

Remove the main cable connector from the BRT (Main PSU cable).
Disconnect the battery cable plug (purple plug).

Disconnect the red + battery cable.
Disconnect the blue – battery cable.

TECHNICAL APPENDICES

SECTION 4

4 Technical appendices

4.1 Equipment scheme description

Below, here is the wiring diagram of the BRT. However, it is a simplified diagram as some components are intentionally missing.

Main switch
Ground disruptor

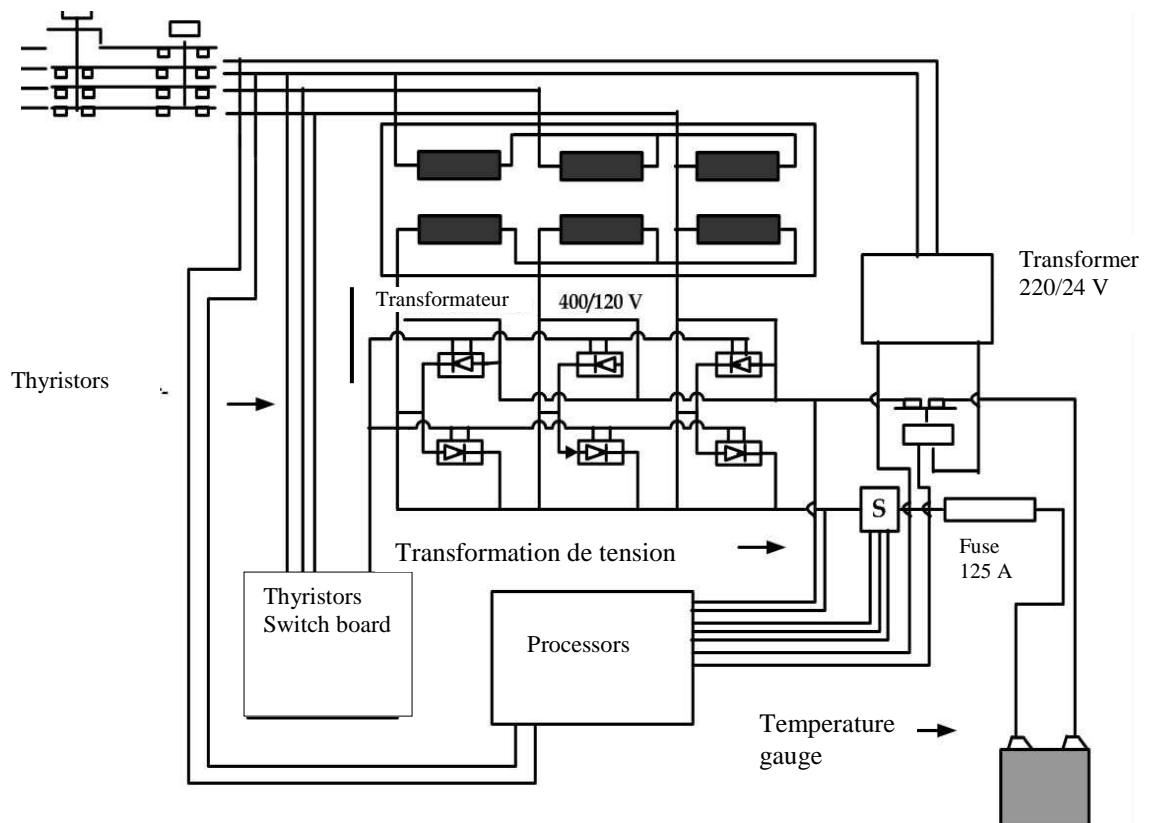

Scheme, S = Current sensor.

4.2 Installation

The BRT is simple to set up. There is anyhow some minimum requirements:

Power supply shall be on three phases 380 to 400 V, disructor 40 A or 50A on a D curve. The BRT requires a lot of energy during very short moment and disructor shall be strong enough to keep current flow during those peak period.

To keep things moving without any trouble, we recommend to increase disructer capacity to 60 Amps.





To get the BRT operational, connection to the main PSU shall respect the phase order (R, S, T) and the main cable shall also be well connected.

As already done for the main connection, European types plug with 3 phases and neutral shall be used.

Manufacturer shall supply a plug with the phase in the right order. Check the phase order after installation.

Upon the impedance of the electric network, it may be required to change the order of the phases.

If phases are not in the correct sequences, the BRT will not work correctly. One can notice misfunctionning as follows:

- Immediate disruption
- Disruption at the first pulse (ie about 2 minutes after connection)
- Pulses with strong amperage gaps.
- Noise at random or chocks during pulse.
- Output : 100%

Then proceed to set up phases in the right order.

This shall be done at the main electric switch board or in the plug. One shall avoid changing the phases in the BRT.

Next step is to control the installation is equipped with differential disruptors such as 300mA one. This machine is equipped with a CEM filter requiring earth connection of 5 mA. It is not required to connect this machine on a disruptor equipped with 300 mA differential (fire protection) or 500mA (machine protection on a dedicated connection).

A 30mA disruptor complying with the human body protection in the working place is sufficient.

The machine is equipped itself with a 30mA disruptor complying with the human body protection.

If the regenerator has been in a long transport please check that all screws are sufficient turned especially those around the transformer.



Wood shocks are placed in the machine to sustain the transformer during shipping while the BRT lies down. Operator shall remove those before using the BRT. Use those shocks again if transport of the machine is needed.

4.3 Maintenance and equipment check list

The BRT is almost maintenance free equipment. Nevertheless, a special care is recommended on the following components:



- -Control the air vent grill on the right hand side of the BRT is dust free,
- -Once switch off and disconnected from the main psu, check all cables connection, mainly if the BRT is often move place to place.,
- -Check the temperature gauge and test if it works when reaching temperature over 45°C.

Double check with a classic thermometer that will be placed temporarily in a cell next to the original gauge.

Another way could also by heating water up to 50 degrees and place the temperature gauge in order to see if the BRT stop processing displaying « High temperature ».

4.4 Checking the temperature gauge connection

Checking this device is quite simple as it is a closed circuit. With a ammeter, check position 1 and 3 without touching the ground which is in the metallic frame. Current should flow between 1 and 3. Pin position as below.

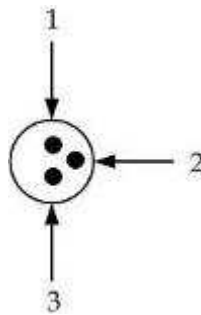



4.5 Breakdown analysis

No problem shall disturb the BRT operation. However here are some advices to cope with potential failures.

4.5.1 Electric interruption

If there is an electric disruption when BRT is started, operator should check the phases order.

If disruption occurs from time to time, check that the BRT is working correctly.

First thing to do : check the card which is right below the BRT top cover where operator can read

Failure code	Failure
FF	Phase failure: no tension in one phase
LU	Tension between R and S too low (Main power supply problem)
LI	Current limitation
Ir	Internal Inhibition activated
Ot	High temperature in the thermo transistors
00	Normal use Thyristors are working correctly.

4.5.2 Regenerator gets overheated

If high temperature of the BRT is noticed check that the air vent system of the thyristors is working.

If not working, the BRT shall not be used and operator should contact the nearest distributor.

4.5.3 Temperature gauge

Sometime sulphuric acid attacks the temperature gauge.

If there is a doubt about it, refer to chapter 4.4 to test the gauge.

Gauge shall be connected to the BRT. If BRT stops and “high temperature” is on the screen display the gauge is working. If nothing happens, then the temperature gauge should be replaced.

If the gauge is not connected, then « high temperature » message appears on the screen display.



4.5.4 Output displays 100 %

This failure may occur while the BRT is in pulsation mode. If power is 100 % it means the circuit is not closed for the following reasons:

- Main BRT fuse (125 A) is dead,
- No battery connected to the BRT
- The battery or one of the battery line is in short circuit
- There is a phase problem.

The main reason would be the fuse of the BRT. Its resistance should be checked



For safety reason, regarding short circuit occurrence in the battery, the BRT will stop after one minute operation if the output remains steady at 100%



CAUTION/ NEVER OPERATE MAINTENANCE ON THE BRT IF IT IS NOT DISCONNECTED FROM MAIN PSU – ELECTRIC HAZARD MAY OCCUR .

If needed, the fuse shall be replaced. Once the fuse change, check up the connection line and the battery in process looking for short circuits.

Indeed, when output is 100% it is possible that a battery cell might be in short circuit.

To check this, set a constant charge loop without pulsation. If after a few minutes amperage doesn't increase and voltage of the battery is over nominal values, operator will have to cope with a battery short circuit.

4.5.5 Regeneraion doesn't start

The BRT doesn't start even though the menu appears on the screen display.
Check if the temperature gauge is well connected.

4.5.6 No electric flow on screen

1- no electric flow on screen, 2- the BRT accumulate a lot of energy till the main fuse burns out. Regenerator will have strange sound showing it is not under control.
Stop the BRT immediately and check if the current sensor is still working.

4.5.7 Worksheet "regeneration test"



MIN – B3 – 135, av Pierre SEMARD – 84 000 AVIGNON cedex FRANCE
Tel. +33 (0)4 90 87 00 07 • Fax +33 (0)4 90 81 08 05

Hereafter examples of regeneration test worksheets for traction, stationnary and starting batteries.



REGENERATION TEST

Description operator:		Description Carrier	
-----------------------	--	---------------------	--

Battery brand		Age		Type	
---------------	--	-----	--	------	--

VOLT		AH		N°	
------	--	----	--	----	--

	VOLT			DENSITY		
Dates						
Cell * 1						
2						
3						
4						
5						
6						
7						
8						
9						
10						
11						
12						
13						
14						
15						
16						
17						
18						
19						
20						
21						
22						
23						
24						
25						
26						
27						
28						
29						
30						
31						
32						
33						
34						
35						
36						
37						
38						
39						
40						

Dates							
Global tension							

* Cells are recorded starting from the battery positive connector

Comments:

Operator:
 Battery qualification :
 Signature

